

CLEO

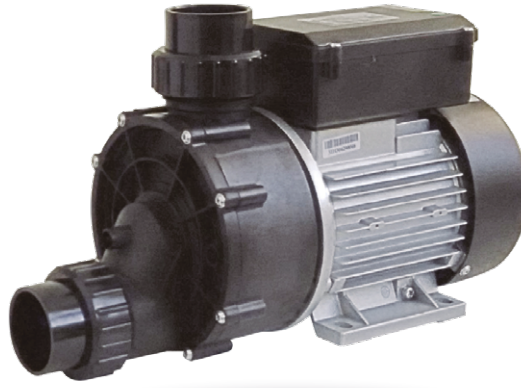

2900
rpm

Bomba que por su diseño y seguridad es ideal para su uso en instalaciones con cascadas, cañones de agua y spas.

- Protección térmica incluida
- Clase de aislamiento: F
- Protección: IP55
- Motor: 50Hz/2900 rpm

MATERIALES

Cuerpo bomba, difusor y turbina:

Polipropileno + FV

Eje: Acero inoxidable AISI 420

Sello mecánico: Carbono

+ Resina - Cerámica

Pump ideally designed for its use with waterfalls, water cannons and spas.

- Thermal protection included
- Isolation class: F
- Protection: IP55
- Motor: 50Hz/2900 rpm

MATERIALS

Pump body and impeller:

Polypropylene + GF.

Shaft: Stainless Steel AISI 420

Mechanical seal: Carbon

+ Resin - Ceramics

Pompe optimal à utiliser en cascades, canons d'eau et spas.

- Protection thermique inclus
- Classe d'isolement: F
- Étanchéité: IP55
- Moteur: 2.900 rpm

MATÉRIAUX

Corps de pompe, diffuseur y turbine:

Polypropylène + FV.

Arbre: Acier inoxydable AISI 420.

Garniture mécanique: Carbono

+ Résine - Céramique.

CLEO 50/75

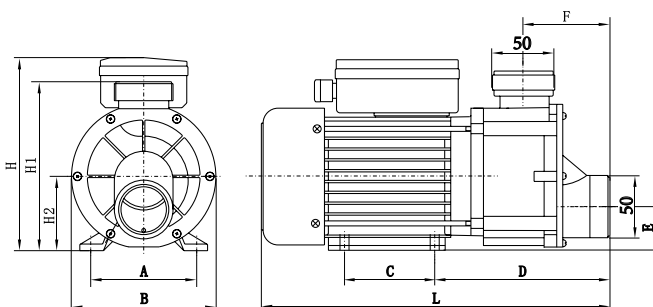

CLEO 100/120/150/200

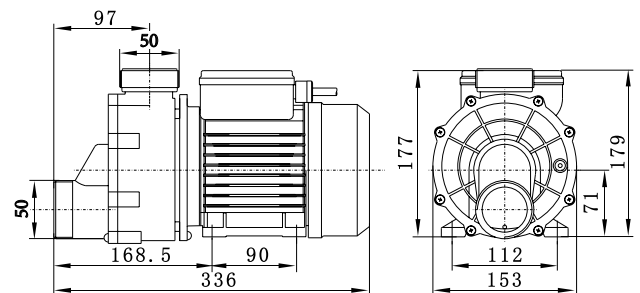

Tipo Type Type	DIMENSIONES / DIMENSIONS / DIMENSIONS (mm)									
	A	B	C	D	E	F	L	H	H1	H2
CLEO-50	100	153	80	164	33	89	317	191	168	63
CLEO-75	112	156	90	172	44	86	347	205	179	74

Characteristics curve

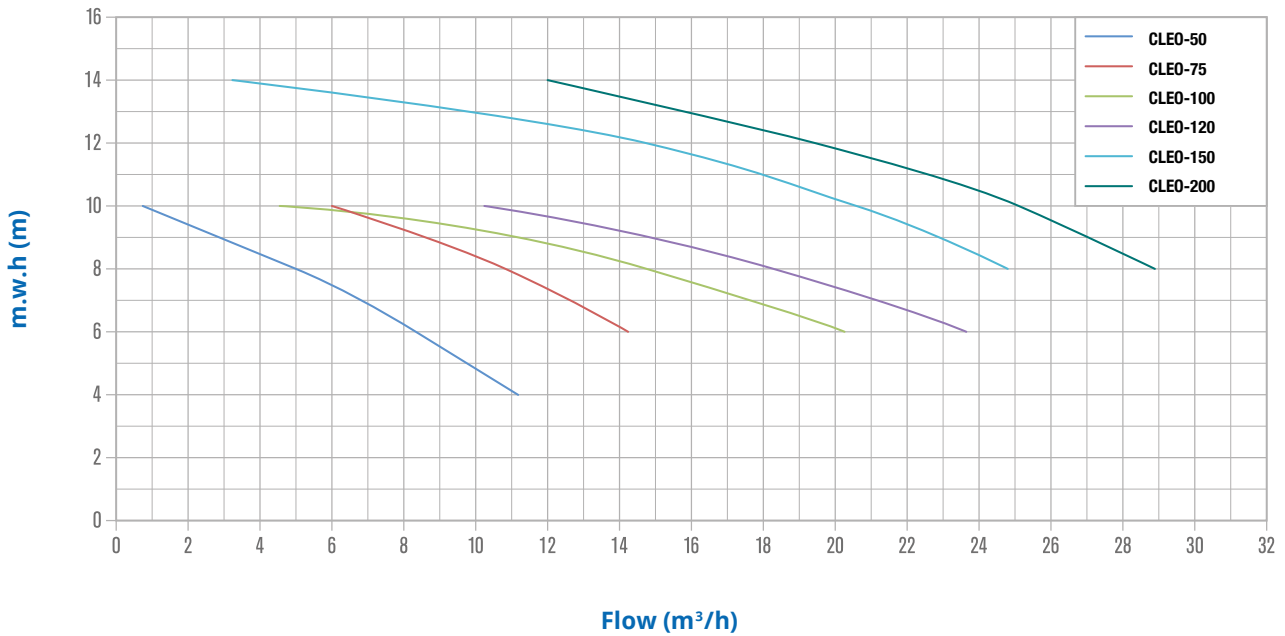

Tipo Type Type	Potencia Power Puissance		Cond. Capac. Cond.		II 230V A	Altura Manométrica / Head / Hauteur manométrique (m)						Peso Weight Poids Kg	
	kW	P ₁ HP	P ₂ kW	HP		μf	4	6	8	10	12		14
Caudal / Flow rate / Débit (m³/h)													
CLEO-50	0,37	0,5	0,25	0,33	7	2,0	11,2	8,4	5,0	0,8	-	-	5,9
CLEO-75	0,55	0,75	0,37	0,5	10	3,2	-	14,2	10,9	6,0	-	-	7,9
CLEO-100	0,75	1	0,55	0,75	10	3,8	-	20,3	14,7	4,5	-	-	8,3
CLEO-120	0,9	1,2	0,65	0,85	20	4,6	-	23,6	18,2	10,3	-	-	8,8
CLEO-150	1,1	1,5	0,75	1	20	5,8	-	-	24,7	20,6	14,8	3,3	9,5
CLEO-200	1,5	2	1,1	1,5	30	7,0	-	-	28,9	25,1	19,4	12,0	10,0